



Features

- 100% oil free
- 100% duty cycle
- Compact and easy to use
- Easy maintenance
- Long-life, 2-year warranty
- 8000 hours cup life at 8bar
- 4000 hours maintenance interval for the dryer

Description

- Built-in 2-column adsorption dryer
- Pressure dew point down to -40°C
- 1µm air filtration (class 2 for dust according to ISO8573.1:2010)
- Pressure regulator included
- Receiver with internal coating and 5-year warranty

OTHER VERSIONS

- Without dryer (OF302-25B)
- With soundproofing cabinet (OF302-25MQ2)

Product Specifications

Model	OF302-25BQ2			
Voltage	V	1x230	1x230	1x120
Frequency	Hz	50	60	60
Motor	HP	0.6	0.6	0.6
	kW	0.44	0.44	0.44
Displacement	l/min	108	138	138
Air flow @ 8bar	l/min	30	36	36
	cfm	1.06	1.27	1.27
Max. pressure	bar	8	8	8
	psi	120	120	120
Max. current	A	3.8	4.1	6.6
Receiver volume	litres	25	25	25
	gallon	6.6	6.6	6.6
Weight	kg	33	33	33
	lbs	73	73	73
Noise level	dB(A)/1m	65	66	66
Duty cycle		100%	100%	100%

Air flow / pressure curve ¹⁾

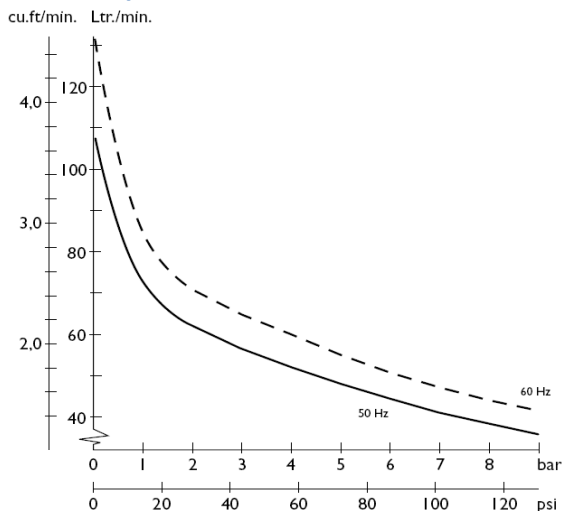

Dimensions - inches / [mm] ²⁾

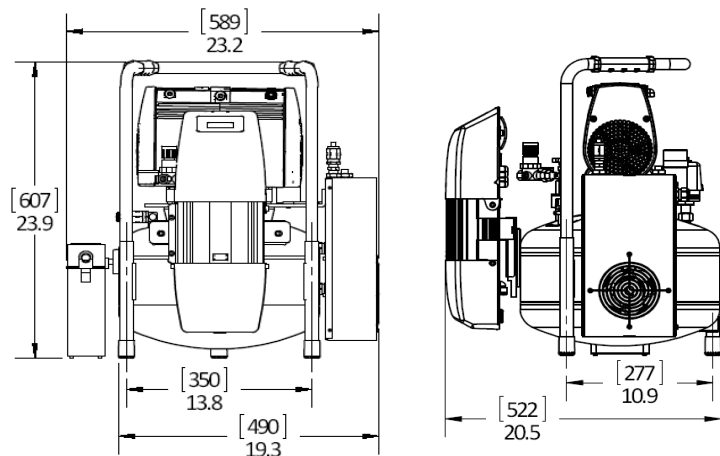

1) air flow is reduced by 18 to 20% on units with dryers

2) for unit without accessories or options