



### Features

- 100% oil free
- 100% duty cycle
- Compact and easy to use
- Easy maintenance
- Long-life, 2-year warranty
- 8000 hours cup life at 8bar

### Accessories

- Automatic drain of the receiver
- Drain bottle

### Description

- 5µm air filtration
- Pressure regulator included
- Receiver with internal coating and 5-year warranty

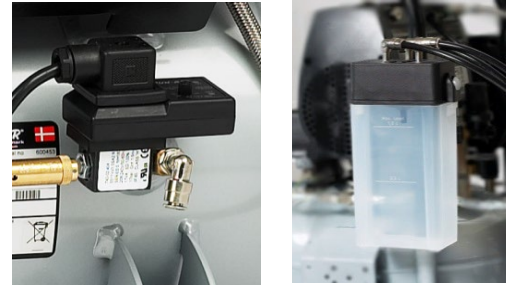

### Product Specifications

Model	OF302-15B			
Voltage	V	1x230	1x230	1x120
Frequency	Hz	50	60	60
Motor	HP	0.6	0.6	0.6
	kW	0.44	0.44	0.44
Displacement	l/min	108	138	138
Air flow @ 8bar	l/min	38	44	44
	cfm	1.34	1.55	1.55
Max. pressure	bar	8	8	8
	psi	120	120	120
Max. current	A	3.8	4.1	6.6
Receiver volume	litres	15	15	15
	gallon	4	4	4
Weight	kg	25	25	25
	lbs	55	55	55
Noise level	dB(A)/1m	65	66	66
Duty cycle		100%	100%	100%

### Air flow / pressure curve

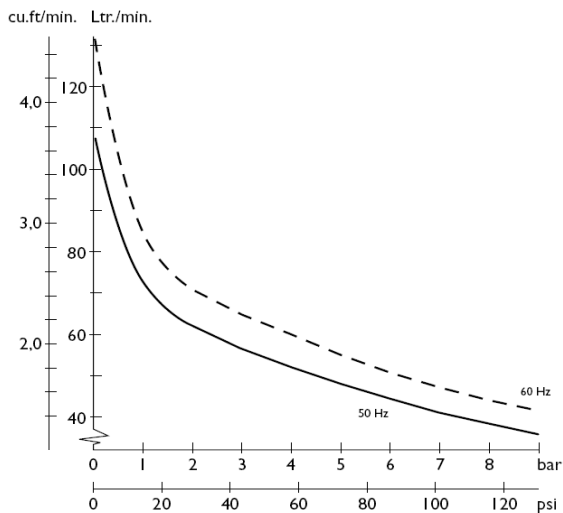

### Dimensions - mm \*

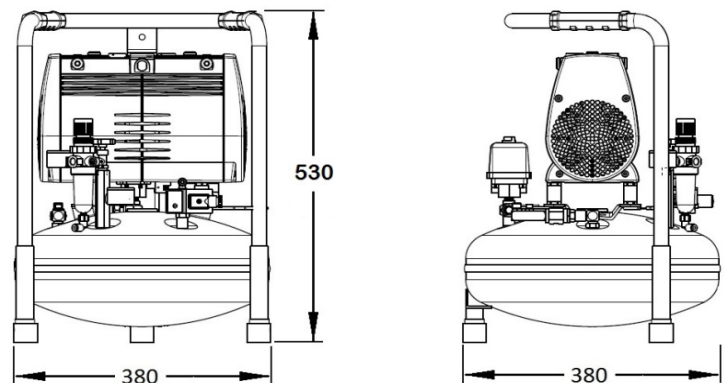

\* unit without accessories