



### Features

- Extremely quiet
- Excellent reliability
- Compact and easy to use
- Easy maintenance
- Long-life, 2-year warranty
- 50% duty cycle

### Description

- 5µm air filtration
- Pressure regulator included
- 5-year warranty on receiver

### Accessories

- 0.01µm filtration
- Receiver autodrain system
- Condensate bottle

## Product Specifications

Model	6-15		
Voltage	V	1x230	1x120
Frequency	Hz	50	60
Motor	HP	0.46	0.54
	kW	0.34	0.4
Displacement	l/min	50	60
Air flow @ 8bar	l/min	32	37
	cfm	1.13	1.31
Max. pressure	bar	8	8
	psi	120	120
Max. current	A	2.9	6.2
Receiver volume	litres	15	15
	gallon	4	4
Weight	kg	26	26
	lbs	57	57
Noise level	dB(A)/1m	45	45
Duty cycle		50%	50%

## Air flow / pressure curve

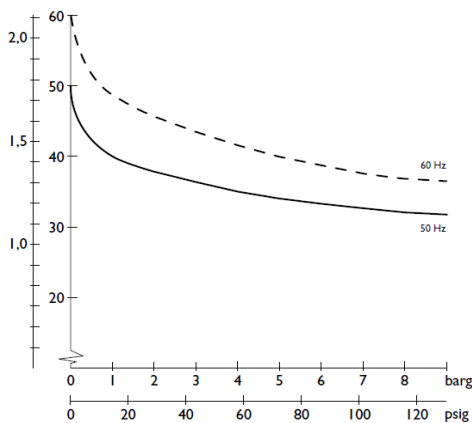

## Dimensions - inches / [mm] \*

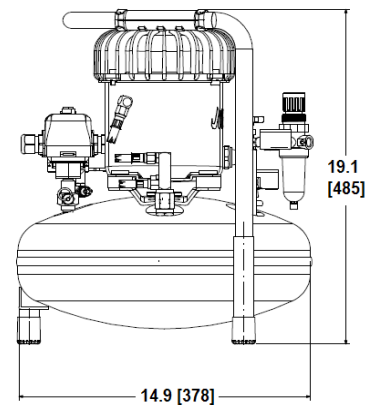
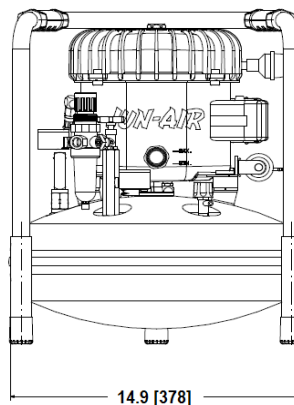

\* for unit without accessories